



# Model 121 Window Discriminator

*Amplitude discriminator for signals in the audio and  
sub-audio frequency range*



## **World Precision Instruments, Inc.**

### **USA**

International Trade Center, 175 Sarasota Center Blvd., Sarasota FL 34240-9258  
Tel: 941-371-1003 • Fax: 941-377-5428 • E-mail: sales@wpiinc.com

### **UK**

Astonbury Farm Business Centre • Aston, Stevenage, Hertfordshire SG2 7EG  
Tel: 01438-880025 • Fax: 01438-880026 • E-mail: wpiuk@wpi-europe.com

### **Germany**

Liegnitzer Str. 15, D-10999 Berlin  
Tel: 030-6188845 • Fax: 030-6188670 • E-mail: wpide@wpi-europe.com

### **Internet**

[www.wpiinc.com](http://www.wpiinc.com) • [www.wpi-medical.com](http://www.wpi-medical.com)  
[www.nitricoxide.net](http://www.nitricoxide.net) • [www.pipetter.com](http://www.pipetter.com)

www.wpiinc.com

## **INSTRUCTION MANUAL**

Serial No. \_\_\_\_\_

082701



**Contents**

Description ..... 1

Operation.....2

Testing .....3

Theory of Operation .....4

Calibration .....5

Warranty .....7

Declaration of Conformity.....9



**WORLD PRECISION INSTRUMENTS, INC.**  
175 Sarasota Center Boulevard  
Sarasota, FL 34240-9258 USA  
Telephone: (941) 371-1003 Fax: (941) 377-5428  
e-mail wpi@wpiinc.com

**DECLARATION OF CONFORMITY**

We: World Precision Instruments, Inc.  
175 Sarasota Center Boulevard  
Sarasota FL 34240-9258  
USA

as the manufacturers of the apparatus listed, declare under sole responsibility that the product(s):

**Title: 121**

to which this declaration relates is/are in conformity with the following standards or other normative documents:

- Safety:** EN 61010-1:1993 (IEC 1010-1:1990)
- EMC:** EN 50081-1:1992  
EN 50082-1:1992

and therefore conform(s) with the protection requirements of Council Directive 89/336/EEC relating to electromagnetic compatibility and Council Directive 73/23/EEC relating to safety requirements.

**Issued on: 18<sup>th</sup> February 2000**

**Dr. Mark P. Broderick**  
**President and COO**  
**World Precision Instruments, Inc.**  
**175 Sarasota Center Boulevard**  
**Sarasota, FL 34240-9258 USA**

**Mr. Glen Carlquist**  
**Production Manager**  
**World Precision Instruments, Inc.**  
**175 Sarasota Center Boulevard**  
**Sarasota, FL 34240-9258 USA**

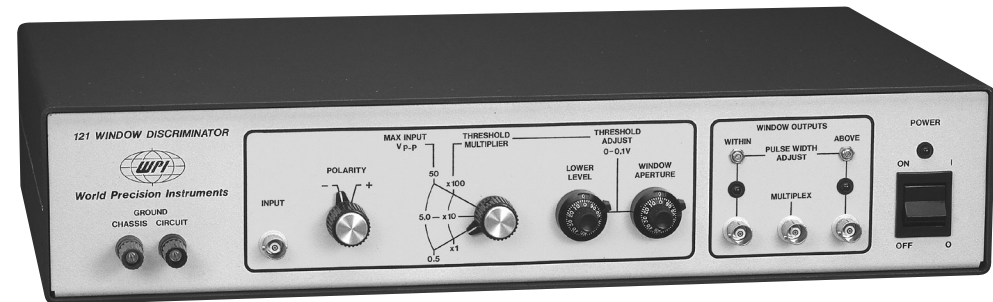

## Description

Model 121 is an amplitude discriminator for signals in the audio and sub-audio frequency range such as EEG and extracellular nerve action potentials. Input signals are sorted according to peak amplitude. For every waveform peak that appears within the window aperture set by the user, a rectangular pulse is generated at the Window output. Signals exceeding the upper level of the window produce outputs at the Above Window output. Visual indication (LED) of the pulses is provided at each output.

Multiplexing the input signal and window discriminator provides convenient visualization and ease of setting up an experiment. The WPI multiplex circuitry samples the input signal and window levels on a 70%/30% basis respectively, thereby minimizing loss of signal information.

Window discriminator levels are easily set. The lower level is set with the Lower Level control. The Window Aperture control sets the upper window level with respect to the lower level setting. Therefore, changing the lower level setting has no effect on the window aperture but simply displaces the window up or down. It is impossible for the user to set the lower level higher than the upper level.

The pulses from either output (Window or Above Window) are coincident with the falling edge of the pulse being analyzed and the level setting. The logic circuit is not time dependent. Therefore, the Model 121 can be used to analyze pulses for any duration. Signals of either polarity can be handled. Input ranges (maximum volts peak to peak) are 0.5, 5.0, and 50 volts. Respective window level ranges are 0-0.1, 0-1.0, and 0-10.0 volts. Ten-turn controls with dial indicators allow for precise setting and direct reading of the window levels.

Operation

Connect the line cord to the appropriate AC voltage outlet, 115 volts 60 Hz or 230 volts 50 Hz. Turn the switch on.

The input signal is applied to the INPUT connector at the left-hand side of the instrument front panel. Since this terminal is capacitatively coupled to the internal circuitry, the DC level of the input signal may be any arbitrary value up to a maximum of ± 50 volts.

The operation of this instrument is unipolar; that is, the window can be set for positive or negative going signals as determined by the setting of the POLARITY switch. Once the POLARITY switch is set either + or -, the circuitry will accordingly operate for waveform elements of the selected polarity.

An amplitude "window" is established by operating the LOWER LEVEL and WINDOW APERTURE controls. Assuming positive polarity is selected (this will be assumed throughout; negative polarity signals operate in a similar manner), the LOWER LEVER control will set lower amplitude of the window in volts as shown on the scale. The Window Aperture control sets the upper window level with respect to the lower level setting. Therefore, changing the lower level setting has no effect on the window aperture but simply moves the window up or down. Both voltage scales are operated upon by the THRESHOLD MULTIPLIER switch.

Figure 1 shows the relationship between the input voltage range, threshold multiplier and the window amplitude range.

Man. Input Volts pk to pk	Threshold Multiplier	Lower Level	Window Aperture
0.5	x1	0-0.1V	0-0.1V
5.0	x10	0-1V	0-1V
50	x100	0-10V	0-10V

Figure 1

Signal "events" which occur within the window's range will generate a rectangular pulse at the WITHIN WINDOW OUTPUT connector. An event is the entry and departure of a signal into the aperture without exceeding the upper level. Two such events are shown in Figure 2. Only one pulse will be generated by each event. A pulse is also generated for those events which exceed the upper level. Pulses coincident with these events are available at the ABOVE WINDOW OUTPUT connector. Visual indication of the output pulses is provided by LEDs located just above each output connector. The width of the output pulses is independently adjustable over a range of 0.1 ms to 1.0 ms. The adjustment is made with the trimpots located above the respective output connector and LED.

Warranty

WPI (World Precision Instruments, Inc.) warrants to the original purchaser that this equipment, including its components and parts, shall be free from defects in material and workmanship for a period of one year\* from the date of receipt. WPI's obligation under this warranty shall be limited to repair or replacement, at WPI's option, of the equipment or defective components or parts upon receipt thereof f.o.b. WPI, Sarasota, Florida U.S.A. Return of a repaired instrument shall be f.o.b. Sarasota.

The above warranty is contingent upon normal usage and does not cover products which have been modified without WPI's approval or which have been subjected to unusual physical or electrical stress or on which the original identification marks have been removed or altered. The above warranty will not apply if adjustment, repair or parts replacement is required because of accident, neglect, misuse, failure of electric power, air conditioning, humidity control, or causes other than normal and ordinary usage.

To the extent that any of its equipment is furnished by a manufacturer other than WPI, the foregoing warranty shall be applicable only to the extent of the warranty furnished by such other manufacturer. This warranty will not apply to appearance terms, such as knobs, handles, dials or the like.

WPI makes no warranty of any kind, express or implied or statutory, including without limitation any warranties of merchantability and/or fitness for a particular purpose. WPI shall not be liable for any damages, whether direct, indirect, special or consequential arising from a failure of this product to operate in the manner desired by the user. WPI shall not be liable for any damage to data or property that may be caused directly or indirectly by use of this product.

Claims and Returns

- Inspect all shipments upon receipt. Missing cartons or obvious damage to cartons should be noted on the delivery receipt before signing. Concealed loss or damage should be reported at once to the carrier and an inspection requested. All claims for shortage or damage must be made within 10 days after receipt of shipment. Claims for lost shipments must be made within 30 days of invoice or other notification of shipment. Please save damaged or pilfered cartons until claim settles. In some instances, photographic documentation may be required. Some items are time sensitive; WPI assumes no extended warranty or any liability for use beyond the date specified on the container.
- WPI cannot be held responsible for items damaged in shipment en route to us. Please enclose merchandise in its original shipping container to avoid damage from handling. We recommend that you insure merchandise when shipping. The customer is responsible for paying shipping expenses including adequate insurance on all items returned.
- Do not return any goods to WPI without obtaining prior approval and instructions (RMA#) from our returns department. Goods returned unauthorized or by collect freight may be refused. The RMA# must be clearly displayed on the outside of the box, or the package will not be accepted. Please contact the RMA department for a request form.
- Goods returned for repair must be reasonably clean and free of hazardous materials.
- A handling fee is charged for goods returned for exchange or credit. This fee may add up to 25% of the sale price depending on the condition of the item. Goods ordered in error are also subject to the handling fee.
- Equipment which was built as a special order cannot be returned.
- Always refer to the RMA# when contacting WPI to obtain a status of your returned item.
- For any other issues regarding a claim or return, please contact the RMA department.

**Warning: This equipment is not designed or intended for use on humans.**

\* Electrodes, batteries and other consumable parts are warranted for 30 days only from the date on which the customer receives these items.

**Specifications**

**Inputs**

- Input Resistance .....100K ohms
- Input Polarity .....Positive or negative, switch selectable
- Input Range (max. input signal) .....Up to 50 volts (peak to peak) in three ranges
  - 0 - 0.5 volts
  - 0 - 5 volts
  - 0 - 50 volts

- Window Level Range  
(both upper and lower levels) .....Up to 10 volts in three ranges
  - 0 - 100 millivolts
  - 0 - 1 volt
  - 0 - 10 volts

- Discriminator Resolution .....0.1 % of full scale (selected range)
- Discriminator Accuracy .....2% on any range

**Outputs**

- Window and Above Window .....Rectangular pulses, approx. 5.0 volts amplitude (TTL compatible), adjustable pulse width from 0.1 to 1.0 millisecond. Output impedance less than 500 ohms. LED indicates presence of output pulse.
- Multiplex .....Cycle length nominally 37  $\mu$ s.  
Signal on time: 26  $\mu$ s (70%)  
Levels on time: 11  $\mu$ s (30%)  
Output impedance less than 100 ohms.
- Power Requirements .....110-120 or 220-250 volts, 50-60 Hz, 10 watts
- Dimensions .....38 cm (w) x 9 cm (h) x 25 cm (d)
- Weight .....2 kg (4.5 lb)

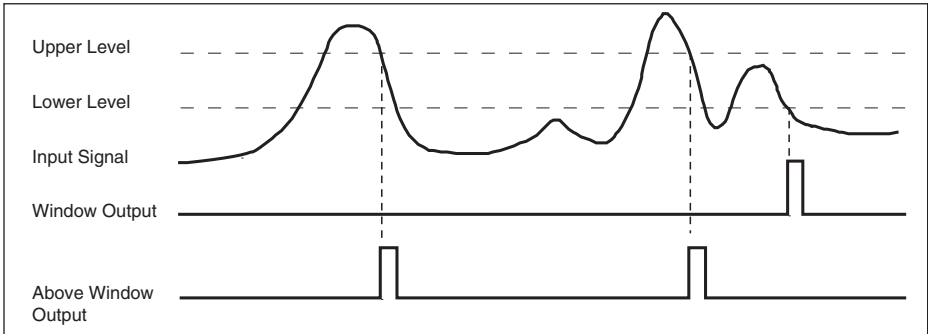

Figure 2

The pulses from either output (Within or Above Window) are coincident with the falling edge of the pulse being analyzed and the level setting as shown above. The logic circuit is not time dependent. Therefore, Model 121 can be used to analyze pulses of any duration.

Multiplexing of the input signal and the window discriminator levels provides convenient oscilloscope visualization and ease of setting up an experiment. The multiplex circuitry samples the input signal and window discriminator levels on a 70%/30% basis respectively, thereby minimizing the loss of displayed signal information. The MULTIPLEX output levels are normalized. That is, the displayed amplitude of the lower discriminator level is always in the range of 0 to 100 mV, irrespective of the setting of the range switch. The same is true for the window aperture. Its range is always displayed as 0 to 100 mV above the lower discriminator level. The displayed amplitude of the input signal is a function of the setting of the range switch. When set to the 0.5 pk-pk position, the input signal passes to the multiplex output without attenuation. The attenuation factor for the 5.0 V pk-pk setting is 10 and for the 50 V pk-pk position the attenuation factor is 100. When observing the multiplex output one must remember that the displayed amplitudes must be scaled by the Threshold Multiplier factor in order to obtain the actual amplitudes.

**Testing**

Set the POLARITY switch to +. Set the THRESHOLD MULTIPLIER to x10. Adjust the LOWER LEVEL to zero volts and the WINDOW APERTURE to .05V (reading of 5.0 on dial). This corresponds to .05V x 10 (Threshold Multiplier) or 0.5V. Connect the MULTIPLEX output to the vertical input of the oscilloscope. Set vertical for DC and sensitivity to 50mV/cm. Set scope horizontal for 1ms/cm sweep speed. Using any standard sine wave oscillator, generate some convenient sine wave signal, for example 200 Hz. Adjust the amplitude of the oscillator to 1 volt peak and connect to the input of the Model 121. One should see a display similar to the one shown in figure 3.

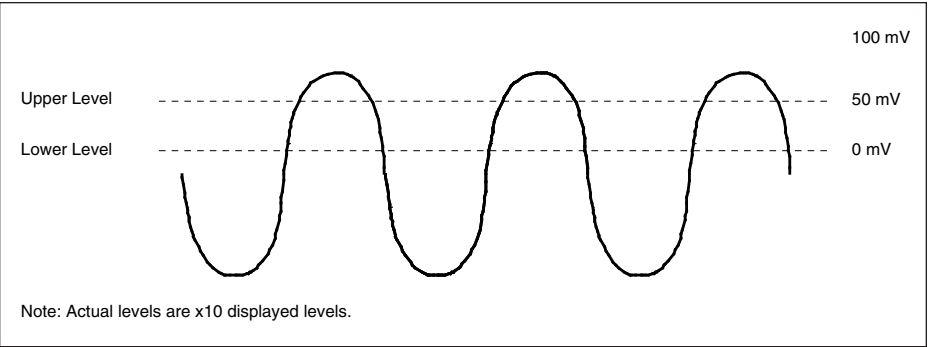

Figure 3

Output pulses will occur on the ABOVE WINDOW OUTPUT connector since in the situation pictured above, all waveform peaks are above the aperture. Also, the ABOVE WINDOW LED will be lit. If one now reduces the amplitude of the input signal to a level within the aperture, pulses will now occur on the WITHIN WINDOW OUTPUT connector and the WITHIN LED will light. If the LOWER LEVEL is now set to 5.0 on the dial, equivalent to an amplitude of .05X 10 or 0.5 V, and the input signal peak is set below this level, no output pulses should occur.

Note that the LED circuitry has an on duration of approximately 3 milliseconds. It is therefore possible to have a continuous indication of window or above window activity if the window or above window pulses are occurring at a rate faster than the 3 millisecond LED on time. The situation can also occur where both LED indicators will be on simultaneously if both within and above window pulses are occurring at a rate faster than the 3 millisecond rate.

**Theory of Operation**

A simplified drawing of the Model 121 circuit in block form is shown in figure 4. The input is first scaled by an input attenuator and then amplified 5 times so as to standardize the amplitude of the input signal. The standardized signal is then fed to two comparators labelled A and B. The other inputs to the comparators come from the threshold control circuit which determines the lower level and aperture amplitudes. The outputs are then operated upon by the digital logic circuitry so that output pulses are steered to the appropriate output connector; that is either within or above window output connectors. Associated with each of the output circuits is an LED which provides a visual indication of the occurrence of an output pulse.

The attenuated input signal and the threshold levels are fed to the buffer and scaler circuit which provides the multiplexer with normalized input levels as previously explained above. The switching signals for the multiplexer are developed by the clock and timing circuitry. The timing is such that the signal is presented to the output for

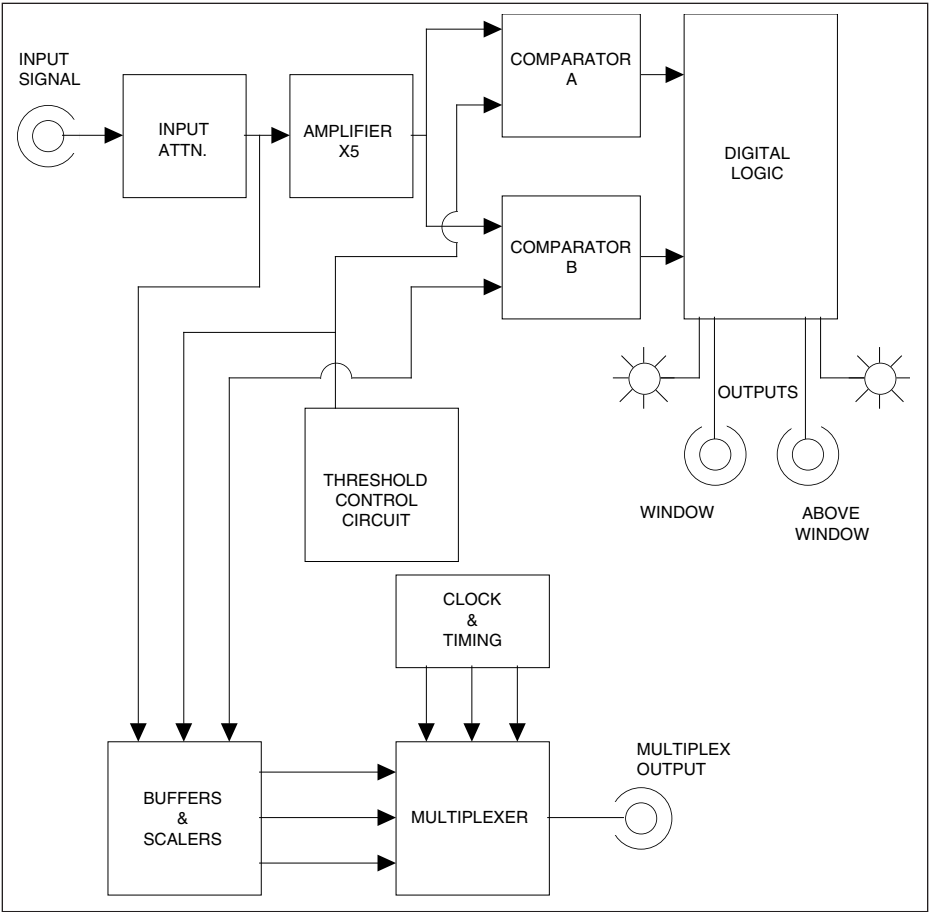

Figure 4

70% of the time and the threshold levels 30% of the time. This arrangement allows multiplexed display of the signal level with a minimum of compromise.

**Calibration**

Under normal operating circumstances no periodic calibration is required. Because of the nature of the circuitry and the calibration procedure involved, it is recommended that recalibration be performed by factory technicians only. In the event that a component is replaced, recalibration may or may not be required. Please consult with the WPI Engineering Department before attempting any recalibration.