

STX2

soaking the electrode in alcohol will weaken the protective coating on the electrode and shorten its lifetime.

In a laminar flow hood

1. Immerse the electrodes in 70% ethanol for 15 minutes. Allow them to air dry for 15 seconds.
2. Rinse the electrode in a sterile electrolyte solution similar to the experimental cell culture medium or in 0.1 µM KCl or 0.15 M NaCl solution.
3. For *resistance* measurements, the electrode is now ready to use.
4. For *voltage* measurements, allow the electrode to equilibrate in the sterile electrolyte for 15 minutes. Then, adjust the "voltage zero" on the **EVOM** to balance any residual offset between the two probes.

The electrode can be left in the UV hood to keep it sterile.

NOTE: When the electrode is exposed to strong visible or UV light, a dark colored oxide film will slowly form on the electrode surface. This film normally will not affect the performance of the electrode. To avoid the formation of the film, shield the electrode from strong light.

STORAGE OF THE ELECTRODE

Short term storage (use within a week or so): Immerse the electrode tip in electrolyte solution. Make sure the electrode cable plug is connected to the electrode port on the **EVOM** meter so that the system is internally short-circuited and electrode symmetry is maintained.

Long term storage (greater than a week or two): When storing for long periods of time, the electrode should be rinsed with distilled water and stored dry and in the dark.

Warranty

WPI (World Precision Instruments, Inc.) warrants to the original purchaser that this equipment, including its components and parts, shall be free from defects in material and workmanship for a period of 30 days from the date of receipt. WPI's obligation under this warranty shall be limited to repair or replacement, at WPI's option, of the equipment or defective components or parts upon receipt thereof f.o.b. WPI, Sarasota, Florida U.S.A. Return of a repaired instrument shall be f.o.b. Sarasota.

The above warranty is contingent upon normal usage and does not cover products which have been modified without WPI's approval or which have been subjected to unusual physical or electrical stress or on which the original identification marks have been removed or altered. The above warranty will not apply if adjustment, repair or parts replacement is required because of accident, neglect, misuse, failure of electric power, air conditioning, humidity control, or causes other than normal and ordinary usage.

To the extent that any of its equipment is furnished by a manufacturer other than WPI, the foregoing warranty shall be applicable only to the extent of the warranty furnished by such other manufacturer. This warranty will not apply to appearance terms, such as knobs, handles, dials or the like.

WPI makes no warranty of any kind, express or implied or statutory, including without limitation any warranties of merchantability and/or fitness for a particular purpose. WPI shall not be liable for any damages, whether direct, indirect, special or consequential arising from a failure of this product to operate in the manner desired by the user. WPI shall not be liable for any damage to data or property that may be caused directly or indirectly by use of this product.

STX2

Claims and Returns

• Inspect all shipments upon receipt. Missing cartons or obvious damage to cartons should be noted on the delivery receipt before signing. Concealed loss or damage should be reported at once to the carrier and an inspection requested. All claims for shortage or damage must be made within 10 days after receipt of shipment. Claims for lost shipments must be made within 30 days of invoice or other notification of shipment.

Please save damaged or pilfered cartons until claim settles. In some instances, photographic documentation may be required. Some items are time sensitive; WPI assumes no extended warranty or any liability for use beyond the date specified on the container.

• WPI cannot be held responsible for items damaged in shipment en route to us. Please enclose merchandise in its original shipping container to avoid damage from handling. We recommend that you insure merchandise when shipping. The customer is responsible for paying shipping expenses including adequate insurance on all items returned.

• Do not return any goods to WPI without obtaining prior approval and instructions (RMA#) from our returns department. Goods returned unauthorized or by collect freight may be refused. The RMA# must be clearly displayed on the outside of the box, or the package will not be accepted. Please contact the RMA department for a request form.

• Goods returned for repair must be reasonably clean and free of hazardous materials.

• A handling fee is charged for goods returned for exchange or credit. This fee may add up to 25% of the sale price depending on the condition of the item. Goods ordered in error are also subject to the handling fee.

• Equipment which was built as a special order cannot be returned.

• Always refer to the RMA# when contacting WPI to obtain a status of your returned item.

• For any other issues regarding a claim or return, please contact the RMA department

Warning: This equipment is not designed or intended for use on humans.



World Precision Instruments, Inc.

USA: International Trade Center, 175 Sarasota Center Blvd., Sarasota FL 34240-9258

Tel: 941-371-1003 • Fax: 941-377-5428 • E-mail: sales@wpiinc.com

UK: Astonbury Farm Business Centre • Aston, Stevenage, Hertfordshire SG2 7EG

Tel: 01438-880025 • Fax: 01438-880026 • E-mail: wpiuk@wpi-europe.com

Germany: Liegnitzer Str. 15, D-10999 Berlin

Tel: 030-6188845 • Fax: 030-6188670 • E-mail: wpide@wpi-europe.com

Internet

**www.wpiinc.com • www.wpi-medical.com
www.nitricoxide.net • www.pipetter.com**



STX2 Electrode

for use with EVOM Epithelial Voltohmmeter

www.wpiinc.com

INSTRUCTION MANUAL

Serial No. _____

040208

World Precision Instruments



The STX2 electrode is designed to facilitate measurements of membrane voltage and resistance (TEER) of cultured epithelia in tissue culture wells. The electrode incorporates a fixed pair of probes, 4 mm wide and 1 mm in thickness. Each probe has an outer and an inner electrode. The outside electrodes are small silver pads that pass current through the membrane sample.

They are referred to as current electrodes and are connected to the I₁ and I₂ pins of the telephone-type plug connector. The internal electrodes are small Ag/AgCl pellet voltage sensors. They are referred to as voltage electrodes and are connected to the V₁ and V₂ pins of the telephone-type plug connector which plug into the **EVOM** or **EVOMX**.

The lengths of the electrodes are unequal allowing the longer (external) electrode to touch the bottom of the dish containing the external culture media while preventing the shorter (internal electrode) from reaching the bottom of the tissue culture cup or insert. This feature ensures proper positioning between the electrode and the cell layer in the cup during the trans membrane measurement. In addition, by positioning the longer tip so that it touches the bottom of the dish each time, the reproducibility of positioning the electrode and therefore the reading on successive measurements, is significantly improved. Even small differences in the apparent fluid resistance may occur if the depth to which the electrode tips are immersed varies.

ELECTRODE SET-UP

For **resistance measurements**, the electrode can be used directly out of dry storage without any preconditioning.

For **voltage measurements**, the electrodes need to be equilibrated to eliminate any offset before use. Electrochemists have long used the following equilibration technique to assure voltage stability and a low inter-electrode potential difference:

The **STX2** voltage electrode pairs are shorted together internally when they are connected to the instrument and the instrument power switch is off. The user may therefore immerse the electrode in electrolyte solution (e.g., 0.1 – 0.15 M KCl) with the electrodes connected to the **EVOM** (Power Off) to allow the probes to equilibrate. With the voltage electrode connector pins thus short-circuited for several hours, the asymmetrical potential difference across the two voltage electrodes is reduced. The inter-electrode DC potential will be a few millivolts or less and quite stable.

The following table lists the recommended equilibration time before using the electrode.

Table 1: STX2 Electrode Equilibration Time

Electrode Condition:	Equilibration Time:
Never tested for voltage drift	24 hours
Stored dry	24 hours
Stored in electrolyte solution	2 hours

INSTRUCTIONS FOR USE

1. Sterilize the electrodes, if desired. (See the Sterilization section under Maintenance for detailed instructions)

2. Place the electrode into the well so the tips just touch the bottom of the wells *without flexing* the electrode (Fig. 1). Ensure that the longer electrode lightly touches the bottom of the outer well and that it remains vertical. *To obtain reproducible results, the position of the electrodes must remain constant. To improve the reproducibility and stability of the measurement, it is important to steady the electrode and be able to reproducibly position it into the well.*

3. When moving the electrodes from one sample cup to another, it is best not to rinse the electrodes with distilled water. Silver/silver chloride electrodes may take several minutes to recover from exposure to distilled water, during which time the potential may drift by a few millivolts. If it is necessary to wash the electrodes between measurements to avoid carryover of one sample into the next, the electrodes should be rinsed with the experimental culture media.

NOTE: Transwell inserts made by Corning Costar, in general, have a greater distance between the bottom of the filter cup and the bottom of the plate. This gap also varies from one lot to the other. It may be large enough to cause the shorter internal electrode to hit the cell layer when the longer electrode touches the bottom of the dish. In this case, the Transwell user can sand 0.5 mm off the shorter electrode.

CAUTION: Only the plastic part of the tip can be sanded. Do not sand any metal part of the tip or damage to the electrode will result. Do not sand the current electrode.

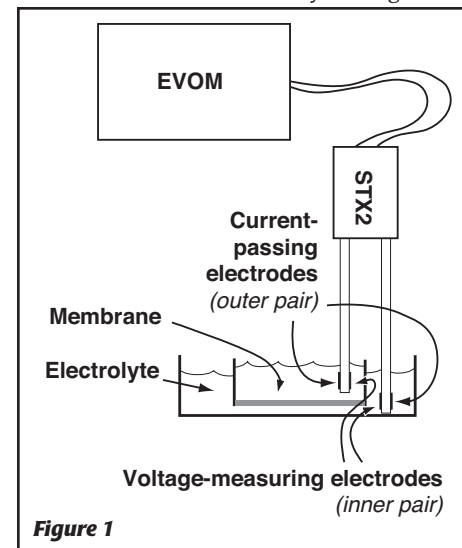

Figure 1

ELECTRODE TEST

To verify the integrity and stabilization of the electrode, mix up 10 cc of 100 mM KCl, 10 cc of 10 mM KCl and 10 cc of 1 mM KCl. When dipped in each vial, the STX2 should produce readings of approximately 7 ohms, 70 ohms and 700 ohms, respectively.

MAINTENANCE OF THE STX2 ELECTRODE

As the Ag/AgCl pellets of the electrodes are solid (entirely composed of Ag/AgCl), there is no need ever to chloride them.

Cleaning

With use, the electrode surface could become coated with foreign materials. This build-up, or contamination, might degrade the performance of the system resulting in slow or erratic voltage readings (resistance readings will probably not be affected).

We recommend three steps to clean the electrode:

- Using a cotton swab soaked with alcohol, lightly rub the surface of the electrode.
- If there is no improvement after following step 1 above, then soak the electrode in undiluted household bleach solution for 3 minutes. Rinse with water immediately after soaking. *Ensure that only the electrode tip is exposed to bleach.* Do not permit the bleach to touch the upper part of the electrode. If additional cleaning is required, go to Step 3.

3. Lightly rub the voltage electrode (silver pellet on the inner surface near the electrode tips) of the **STX2** with the 600-grade ultra-fine sandpaper provided (Fig. 2). Only a very thin surface layer of the pellet should be removed. Repeated sanding will eventually remove the Ag/AgCl pellets. When rubbing no longer improves the voltage readings, the electrode should be replaced. In the absence of 600-grade sandpaper, an ink eraser may be substituted to clean the electrodes.

Sterilizing the STX2 electrode

The **STX2** electrode is non-sterile as supplied. The electrode cannot be sterilized by autoclaving. It may be sterilized using alcohol (one of the most common methods), ethylene oxide, UV, or a bactericide, e.g., **Cidex Plus** (WPI #7364) or Sporicidin.

CAUTION: Do not flame electrodes. Doing so will cause them to melt and invalidate any warranty.

A typical sterilization protocol using alcohol

Do not leave the electrode in alcohol for more than 30 minutes each time. Continuously

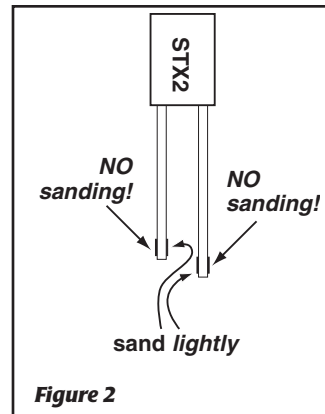

Figure 2